Tyre Changer

Operating Instruction



Preface:

Thank you for buying our semi-automatic tyre changer. It is the best quality .In order to proper operation and extended the lifetime, pls read the instruction for each operation section carefully.

The data of semi- automatic tyre changer:

Provide the “complete product code” and the” model of semi-automatic tyre changer”, so that we can provide you the technical services and required parts betterly .At the same time, easy to operate the machine as technical parameters .If the data in the specification is inconsistent with the label, please refer to the label.

This manual is an indispensable part for machine operation before using the machine, you should read each part of the manual carefully, The operation safety and maintenance parts are necessity.



Save this manual for future using!

1. Description of equipment

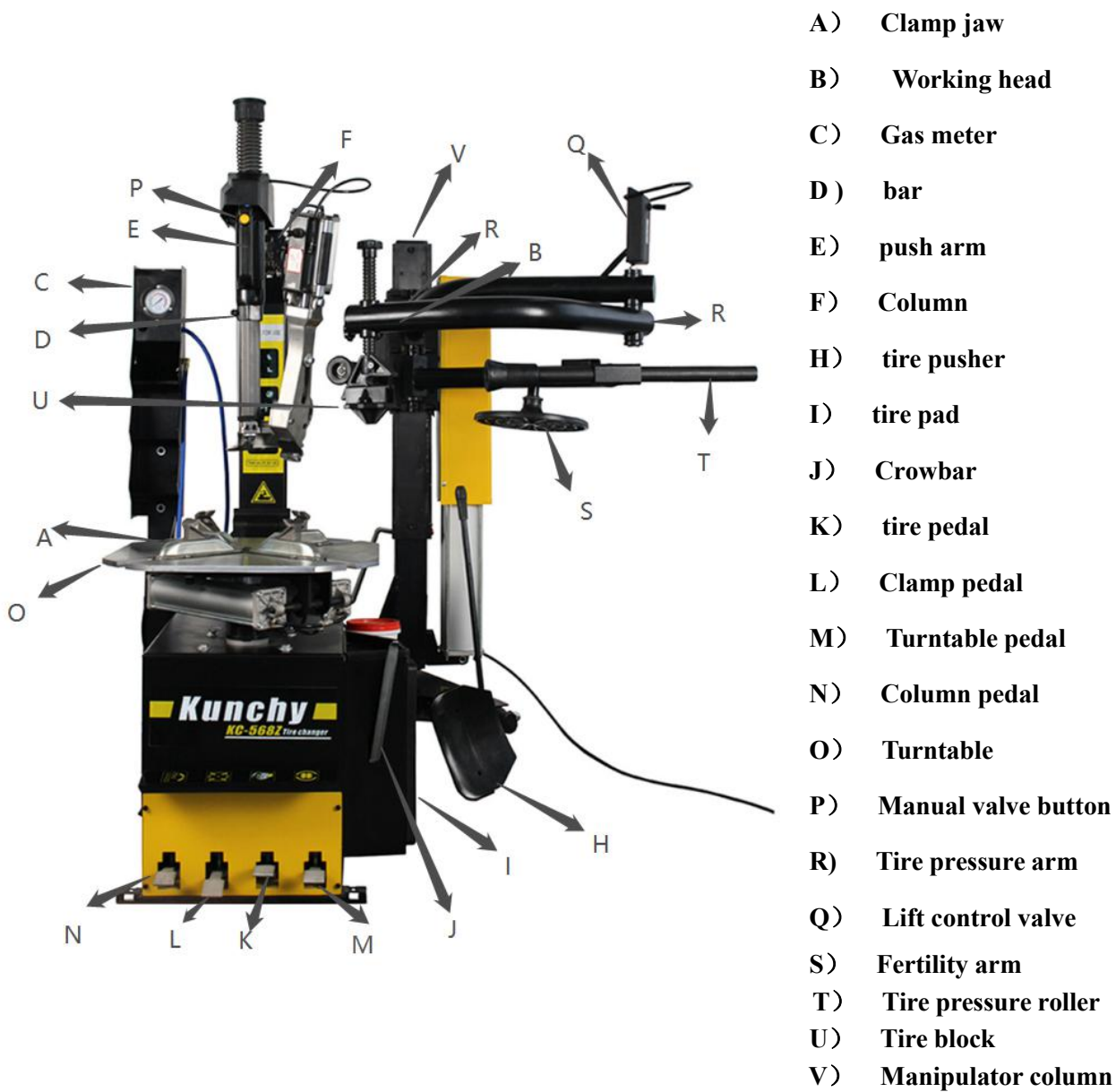

Pic.1

2. General description

2.1 Operation instruction

- The semi-automatic tyre changer is designed to facilitate to mount and demount the tires which the rim sizes is from 10 "to 24" and the maximum diameter of 1,040 mm.



Operation against instruction is prohibited.

- The manufacturer shall not be liable for damage resulting from non-compliance with the instructions.

2.2 Safety operation rule



The semi-automatic tyre changer must be operated by trained personnel.

- The manufacturer shall not be liable for any damage caused by modification of the machine without the manufacturer's approval.
- Manufacturers will immediately discontinue their safety commitments if the user breaches safety rules and causes damage of the machine's safety devices.
- If there is any damage to the safety warning sign during the whole process, the customer can contact the manufacturer according to the icon on page 3 to replace the damaging icon as soon as possible.

3. Transport

- The semi-automatic tyre changer must be transported with the original packaging. Place as indicated on the packing box.
- Move the packed machine by a forklift truck with corresponding lifting capacity.

4. Open package operation

- Open protective boxes and plastic bags.
- Refer to figure 1 to check whether the machine surface is intact and the parts are missing and damaging.
- If any problem is found, please do not use the machine and contact the supplier immediately.

5. Installation instruction

5.1 Space required

The installation position of the machine must meet the standard of safe working.

- The semi-automatic tyre changer should be placed near the main power supply and compressed air system.
- The minimum space of the installation position shall not be lower than the space that be shown in figure 4 and figure 4/A to ensure normal operation without any restriction.
- If the machine is installed outdoors, a protective shelter must be built.



The semi-automatic tyre changer is prohibited to use in explosive gas

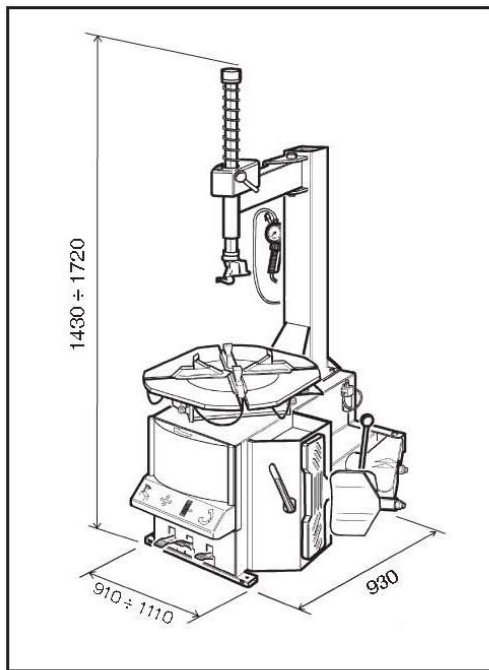

Pic. 3

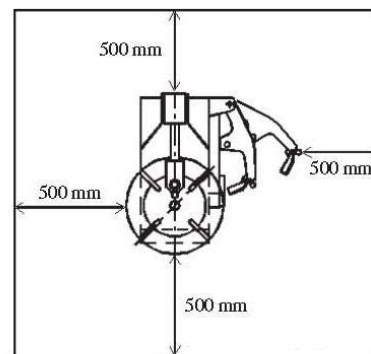

Pic. 3/A

5.2 Installation of components



Before turning on the machine, make sure that the user's power and air source

are consistent with the machine's requirements.

When the operating voltage of the machine needs to be changed, the terminal board can be adjusted appropriately. (Refer to circuit diagram)



The work of the electrical system must be performed by professionals.

- Connect the compressed air system to the machine through the pipe joint (G) on the lubricator on the side of the box. See figure (4)
- To connect the machine to the circuit, the circuit must be equipped with a fuse and grounding wire that comply with the operating rules, and a 30mA automatic circuit breaker must be installed.

Note: The power plug of the tire changer must be prepared by the customer. The rated current of the power plug must not be less than 16A, and it must meet the voltage of the machine.

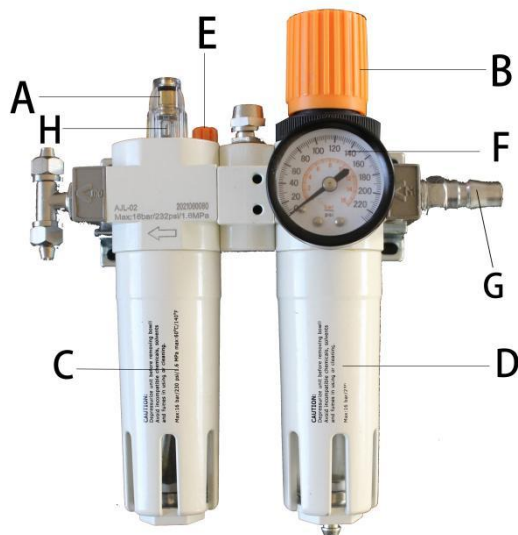

- | | |
|----------------------------------|-------------------------------|
| A: Oil volume adjustment screw | E: Oil filling hole |
| B: Air pressure regulating valve | F: Air pressure gauge |
| C: oil cup | G: inlet pipe joint |
| D: Water cup | H: Oil dripping visual window |

Pic. 4

Oil filling method:

Method 1: Cut off the air source, unscrew the oil filling hole screw and use a needle tube to fill the oil inside

Method 2: Cut off the air source, unscrew the oil cup C clockwise and pour oil directly into the cup

Note: The oil should preferably be a special oil for lubricator or ISO HG with a viscosity of ISO VG32.

5.3 Debugging

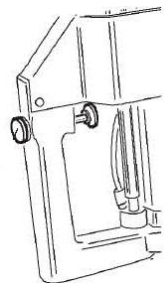

Position 1

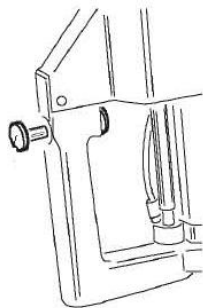

Position 2

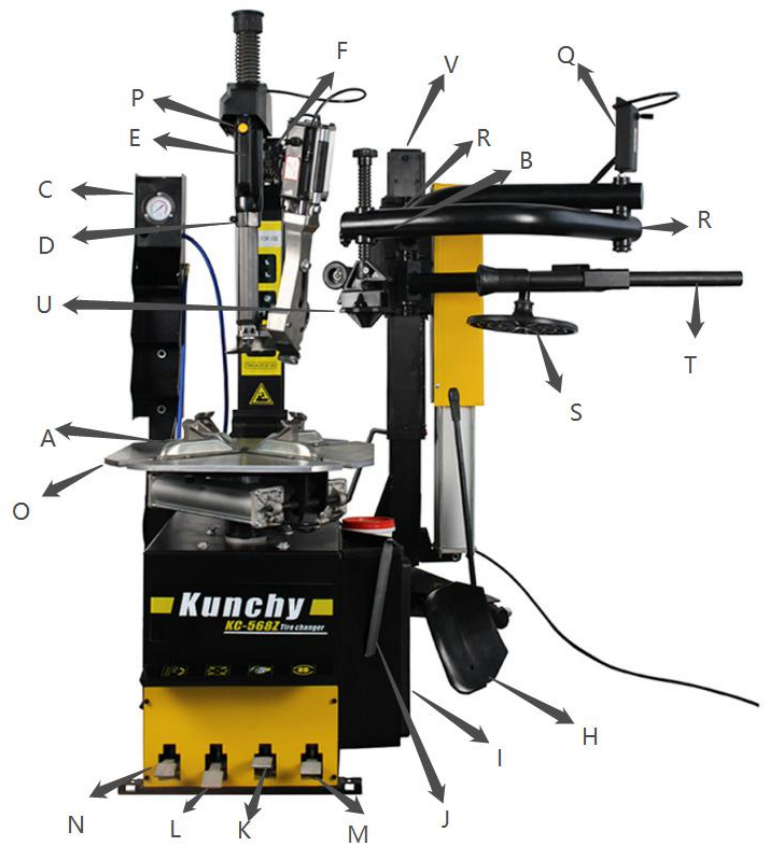

Pic. 5

- Step on the pedal (M) and the turntable (O) should rotate clockwise. When the pedal is raised, the turntable should turn counterclockwise.

Note: If the rotation direction of the turntable is opposite to the specified direction, the two wires of the three-phase plug need to be exchanged.

- Step on the pedal (K) to start the tire pressing device (H); when the pedal is released, the tire pressing device returns to its original position.

- Step on the pedal (L) to open the 4 clamps (A); step on the pedal again to close the clamps.

- Step on the pedal (N) and the column (F) tilts back, and the column (F) returns to its original position when the pedal is released.

- When the manual valve button (P) is in position 1, the hexagonal bar and the push-pull arm are locked, and the disassembly and assembly head is automatically located in the working position.

- When the manual valve button (P) is in position 2, the hexagonal bar and push-pull arm are released.

- Press the exhaust valve button (C) on the inflation pressure gauge box to allow air to be discharged from the inflation pressure gauge pipeline.

5.4 Adjust the position of the turntable clamp

- The turntable clamp of the tire changer has been adjusted to the middle position before leaving the factory. The outer rim size ranges from 12" to 22", and the inner support rim size ranges from 13" to 24".
- If you encounter a larger or smaller rim, you can adjust the positions of the 4 clamps, as shown in Figure 6.

Adjustment range:

The size of the outer rim of the card is from 12"-22".

The inner support rim size is 13"-24".

The specific operations are as follows:

- Unscrew the screw (1) with a universal wrench.
- Move the fixture (2) and the sliding part (3) so that their position matches one of the screw holes of the required locking size.
- Tighten the screws, the torque of the allen wrench must be 72 N.m.

Note: When performing the above-mentioned fixture adjustment operations, avoid the inconsistency of the positions of the 4 fixtures with each other.

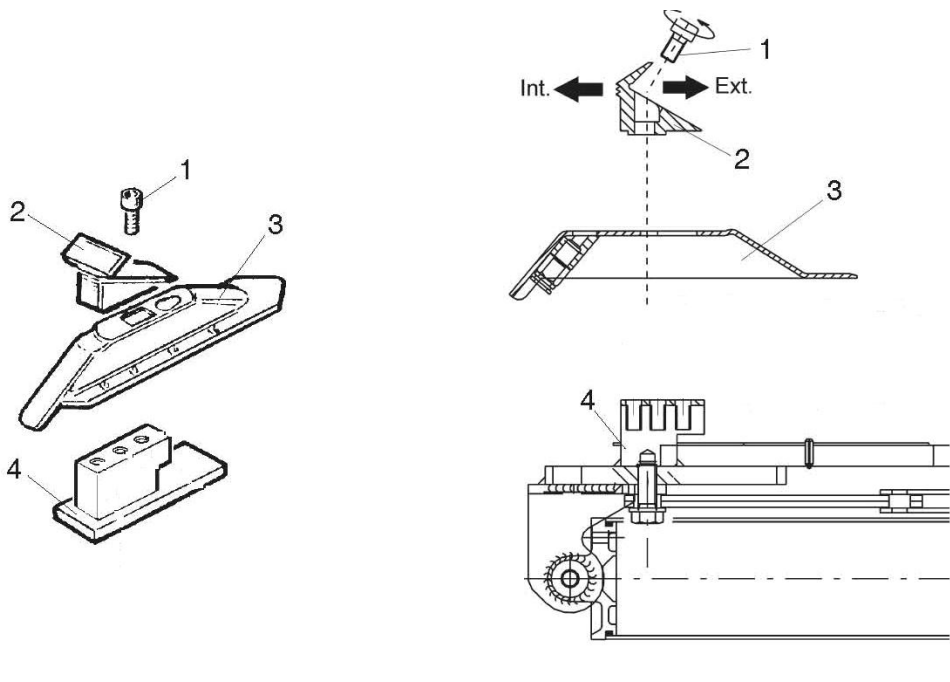

Pic. 6

6. Using



The machine can be operated after carefully reading the entire manual and precautions.

The use of the automatic tire disassembly machine is divided into the following three parts: A) tire pressure B) tire disassembly C) tire assembly



Before operating, let out all the air in the tire and remove the balance weight of the tire balance device.

Precautions for use:

- More and more motorcycle rims are made of special materials such as aluminum-magnesium alloy and carbon fiber. In order to lock this type of rims, it is necessary to use matching repair tools for motorcycle tires.
- In order to avoid unnecessary damage, the turntable clamp is equipped with a plastic protective cover.

6.1 Flat tire



You must be very careful when performing tire compression operations. When the tyre pressure pedal is operated, the tyre pressure shovel arm will swing quickly and forcefully, and any objects within the scope of the tyre pressure shovel arm are in danger of being crushed.

- Check whether the tire has been exhausted, if not, exhausted
- Completely close the clamps of the turntable.

During the operation of the turntable, do not put your hands on the sidewall of the tire, as



the clamp may be pressed when the clamp is in the open state.

- Lean the tire on the tire pressure pad (I) on the right side of the automatic tire changer.
- Place the tyre shovel close to a place 1cm away from the edge of the rim (Figure 7). It should be noted that the tire shovel should be placed on the tire and not on the rim.
- Step on the pedal (K), start the tire pressing device, and release the pedal when the tire pressing shovel completes the operation or the rim is off the rim.
- Gently rotate the tire and repeat the above operations on other parts of the tire until the rim is completely separated from the rim. Repeat the same operation on the other side of the tire.

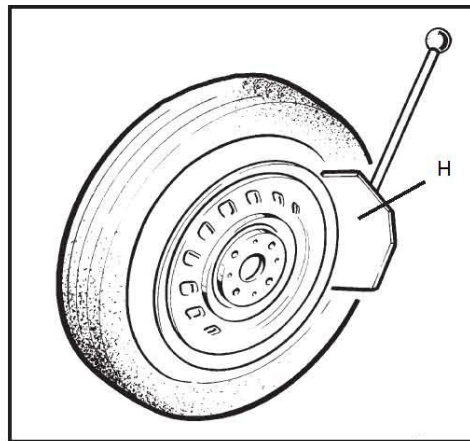

Pic. 7

6. 2 Disassemble tires



Before any operation, check whether the tires have exhausted air. And make sure that the balance weight on the balance device has been removed from the rim.



Make sure that there is no one behind the tire changer before swinging the column back!

- Step on the pedal (N) to tilt the back swing of the column, and the space above the turntable is exposed.

-
- Apply special lubricating fluid to the rim.



Failure to apply lubricating fluid can cause damage to the rim.



When tightening the rim, do not put your hands under the tire.

In order to lock the tire correctly, the tire should be placed in the center of the turntable.

External card locks 12-22 inch tires

- Depress the pedal (L) to the middle position, and position the clamp (A) according to the reference scale of the turntable.
- Place the tire on the fixture, make the rim close to the lowest part of the fixture, and depress the pedal (L) to the end.

Inner support to lock 13-24 inch tires

- Close the clamp (A) completely.
- Put the tire on the clamp, step on the pedal (L) to open the clamp, and lock the rim.



Make sure that the rim is locked by the clamp.



Do not put your hands on the tires: If you put your hands between the rim and the disassembly head, you may be injured when the operating arm returns to the working position.

- Step on the pedal (N), and the column (F) will return to its original position.
- When the manual valve button (P) is in position 2, the hexagonal bar (D) moves down, and the disassembly and assembly head touches the rim.
- When the manual valve button is in position (1), the hexagonal bar (D) and push-pull arm (E) are locked. During the locking process, the disassembly and assembly head can automatically move to a distance of 2mm from the rim in both vertical and horizontal directions. (See Figure 8)



Do not put your hands on the tires: If you put your hands between the rim and the disassembly head, you may be injured when the operating arm returns to the working position.

- Insert a crowbar (J) between the wheel flange and the disassembly head, and use the crowbar (J) to hang the wheel flange outward on the disassembly head.

Note: If there is an inner tube, in order to avoid damage to the inner tube, the tire valve should be placed about 10cm from the right side of the dismounting head (I) to start the dismounting operation.



During the tire removal process, keep hands and other parts of the body away from moving parts as much as possible to avoid injury. Necklaces, bracelets and loose clothing are dangerous for operators!

- Keep the crowbar in this position, step on the pedal (M) and turn the turntable (O) clockwise until the tire is completely removed from the rim. (Picture 8)
- If you need to remove the inner tube, you don't need to unlock the operating arm. Step on the pedal (N) and tilt the operating arm back to remove the inner tube.
- Repeat the same operation above on the other rim.

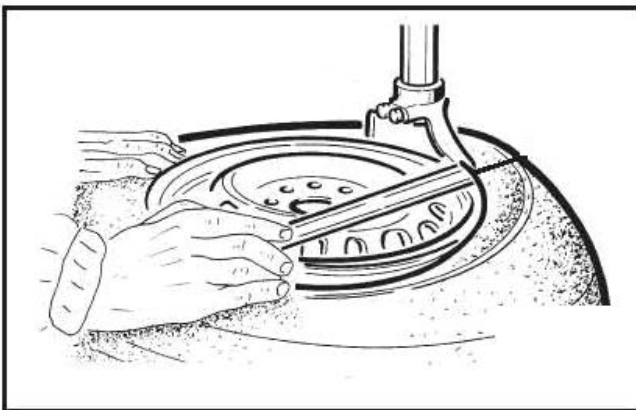

Pic. 8

6. 3 Assemble tires



Note: In order to prevent the tire from bursting during inflation, it is very important to check the tire and rim. Before assembling the tire, pay attention to:

- If the tire surface is damaged, do not install it.
- Whether the rim is sunken or deformed. Especially for alloy rims, there will be small cracks in the convex marks, which are generally indistinguishable by the naked eye, which will damage the durability of the wheel, so it will be dangerous during the inflation process.
- The diameters of tires and rims must match. Do not install the tire when you are not sure that the diameter of the tire and the rim are the same.

- In order to avoid tire damage and facilitate disassembly and assembly, lubricating fluid needs to be applied to the rim of the wheel.

- Tighten the rim on the turntable.



**When tightening the rim, do not put your hands under the tire.
In order to lock the tire correctly, the tire should be placed in the center of the turntable.**



Make sure that there is no one behind the tire changer before the post swing operation can be performed.

Note: For the rim of the same size, it is not necessary to repeatedly lock or loose the operating arm, just tilt the operating arm backward or reset it in the working position.



Do not put your hands between the rim and the fixture to avoid personal injury.

- Move the tire so that the rim passes under the front of the disassembly and assembly head, and along the disassembly and assembly head, the rim is above the rear of the disassembly and assembly head.

- Press the rim of the wheel into the groove of the rim by hand, step on the pedal (M) and rotate the turntable clockwise until the rim completely falls into the rim.



To prevent accidents, keep your hands and body away from the operating arm when the turntable is running.

- If there is an inner tube, insert the inner tube. Repeat the above operation to install the upper rim of the tire.



In the process of tire removal or installation, the turntable always keeps rotating clockwise; if it rotates counterclockwise, it indicates that the turntable is malfunctioning or the operator has made a mistake.

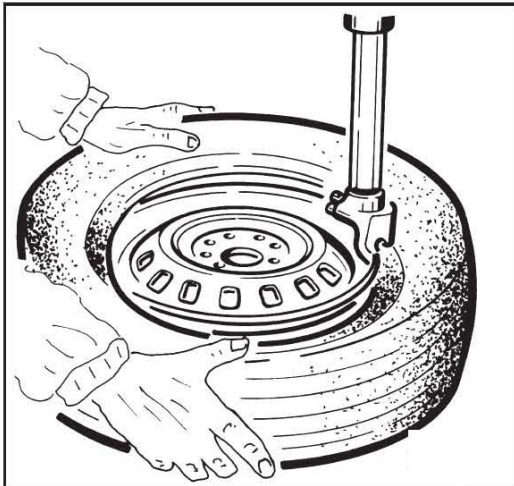

Pic. 9

7. Inflate



You must be very careful when inflating the tires, and operate strictly according to the following instructions. If the tire bursts suddenly, the design and structure of the tire changer cannot protect the personal safety of the operator (or anything near the machine).

⚠ DANGER



- The burst of the tire or the fracture of the rim under pressure may cause serious injury or even death of the operator.
- Check whether the size of the rim is the same as the size of the tire before installing the tire.
- Before starting to inflate, check the usage of the tires to see if there is any damage.
- When using an inflation nozzle to inflate a tire, always check the inflation pressure.
- The maximum inflation pressure of all tires is 3.5bar. Never exceed the pressure recommended by the manufacturer.
- During inflation, keep your hands and body away from the tire as much as possible.

7.1 Inflate the tire with an inflator

The tire changer is equipped with an inflation pressure gauge for tire inflation.

To inflate the tire, follow the steps below:

- Connect the inflation nozzle connector to the tire valve.

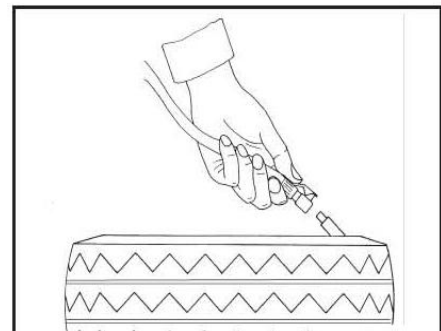

Pic. 10

- Finally, confirm whether the tire is consistent with the diameter of the rim.
- Check whether the rim and rim are coated with enough lubricating fluid.
- Press and release the trigger of the inflation nozzle. During this process, control the inflation pressure until the tire fits on the rim completely.
- Continue to inflate and check the inflation pressure frequently until the pressure reaches the manufacturer's requirement.

Risk of bursting:

▲ DANGER



- **Do not exceed the tire pressure value recommended by the manufacturer: 3.5bar**
- **Remove the tire from the turntable. If you need more inflation pressure, you can place the tire in a special protective cage to continue inflation.**
 - **Do not exceed the maximum allowable inflation pressure.**
 - **Keep your hands and body away from the tire as much as possible.**
 - **Only professionals are allowed to use this machine. During the inflation process, no other people are allowed to use or approach the machine.**

8. Reposition

In order to move the fully automatic tire changer, a forklift is required.

- Disconnect the circuit and compressed air system.
- Insert the crowbar into the side of the bottom of the tire changer to keep the machine off the ground, insert the fork of the forklift from the bottom of the tire changer, and lift it up.
- Put the tire changer in the new location.

Note: When choosing a place to relocate the tire changer, it must comply with national regulations on work safety.

9. Store

If the tire changer needs to be stored for a period of time, you need to do the following:

Disconnect all energy supplies, and lubricate the slides of the fixture on the turntable to prevent oxidation.

10. Scrapped

When deciding to scrap the equipment, make sure that all energy supplies have been disconnected.

-
- Dispose of all non-ferrous metals and non-metals in accordance with relevant laws and regulations.
 - Dispose of the oil stored in the machine at the location specified by the corresponding law.
 - Discard the remaining iron-containing parts.

11. Repair and maintenance

11.1 Warning

Non-professionals are prohibited from performing repairs and maintenance operations.

- In order to prolong the service life of the tire changer, it is necessary to carry out daily repairs and maintenance according to the requirements of the manual.
- If repairs and maintenance are carried out irregularly, the operation and reliability of the machine cannot be guaranteed, and it may even cause danger to the operator or people near the machine.



Before carrying out any maintenance operations, disconnect the circuit and the air supply device and turn off the switch.

In addition, in order to release the pressurized air from the pipeline, it is necessary to step on the tire pressure pedal 3-4 times.

- Professionals will promptly replace damaged parts with original spare parts.
- The unauthorized disassembly or replacement of safety devices (safety valves, regulating valves) violates national regulations on work safety.



In particular, the manufacturer is not responsible for any damage caused by the user's use of other manufacturers' parts or due to the disassembly or damage of the safety device.

11.2 Maintenance

- Clean the turntable with diesel every week to prevent the formation of dirt; apply lubricating oil on the slide of the fixture.
- Carry out the following maintenance operations every 30 days:

Control the level of oil in the lubricator. If the level is low, you need to unscrew the oil cup before adding it. Only use the oil with the specified type of ISO HG and viscosity of ISO VG32, such as:

ESSO Febis K32, MOBIL Vacouline 1405, KLUBER32.

When stepping on the tire pressure pedal 3-4 times, check whether any oil droplets enter the visible window H of the oil cup. If not, adjust screw A. See figure (5)

Note: 20 days after the first use, re-tighten the clamps and the screws on the turntable slide. (Picture 11)

Note: If the horsepower of the machine is not enough, follow the steps below to check the V-belt of the motor: Before proceeding, disconnect the power supply.

- Unscrew the 4 fixing screws, and remove the left side guard plate of the semi-automatic tire changer.

- Use the special adjustment screw X on the motor support to tighten the triangle belt. (Illustration 12)

Note: If the disassembly and assembly head is not locked or can not stop at a position 2mm above the rim, the locking plate of the operating arm needs to be adjusted, as shown in Figure 14.

If the dismounting head is too far away from the rim in the horizontal direction, adjust the adjustment screw of the locking plate of the push-pull arm as shown in Figure 15 so that the dismounting head is 2mm from the rim in the horizontal direction.

Note: When cleaning or replacing the muffler with the control fixture (A) opened and closed (refer to Figure 16), the steps are as follows:

- 1) Unscrew the 4 fixing screws, and remove the left side guard plate of the semi-automatic tire changer.

- 2) Unscrew the muffler in the pedal (L) system that controls the opening and closing of the clamp (A).

- 3) Use a compressed air nozzle for cleaning, if it is damaged, replace it with the same parts.

Note: When cleaning or replacing the muffler of the tire pressing device (L), refer to Figure 16, and the operation steps are in accordance with points 1 and 3 above

Note: When cleaning or replacing the muffler of the tire pressing device (L), refer to Figure

16, and the operation steps are in accordance with points 1 and 3 above

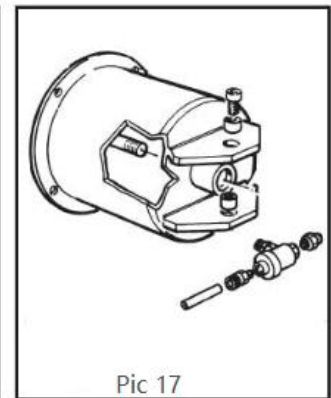
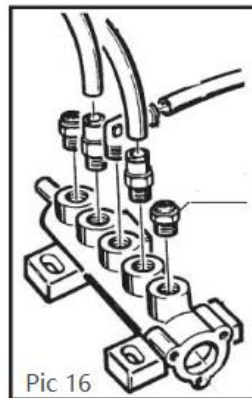
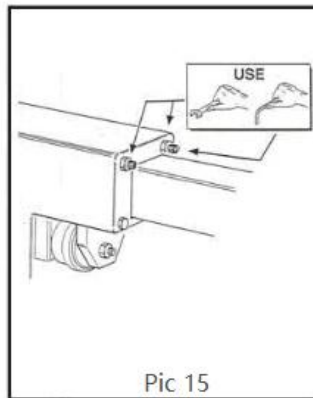
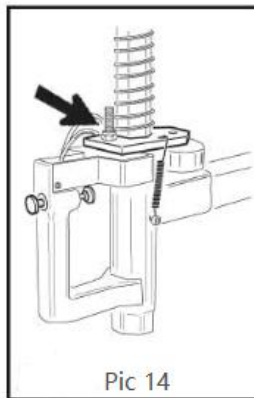
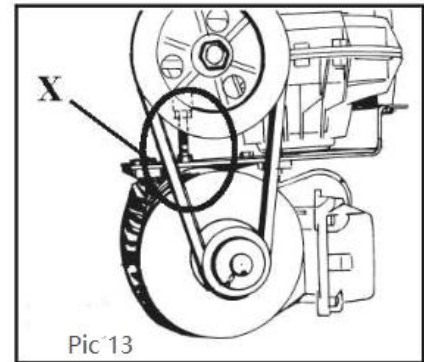
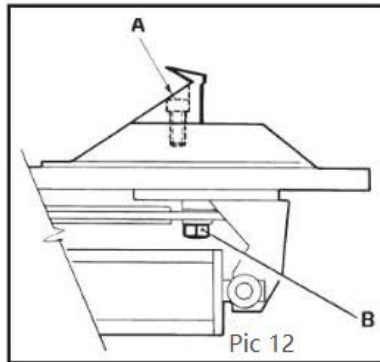
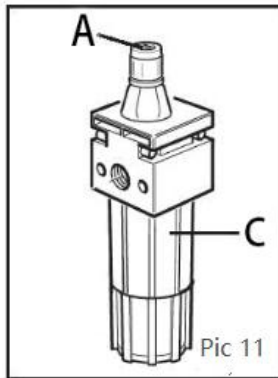

12. Faults and troubleshooting methods

Trouble phenomenon	Cause	Solution
Turntable rotates in one direction	The universal steering switch is damaged	Universal steering switch
The turntable does not rotate	1. The triangle belt is damaged 2. The universal steering switch is damaged 3. Motor failure	1. Replace the triangle belt 2. Replace the universal steering switch 3. Replace the motor
Turntable stuck	V-belt loose	Adjust the tension of the V-belt
Slow opening/closing of clamps	Muffler failure	Clean or replace
The turntable can't lock the rim correctly	1. The fixture is damaged 2. The turntable cylinder is damaged	1. Replace the fixture 2. Replace the cylinder sealing ring

In the process of disassembling and assembling the tire, the disassembly and assembly head touches the rim	<ol style="list-style-type: none"> 1. The position of the locking plate is incorrect or damaged 2. The turntable clamp screw is loose 	<ol style="list-style-type: none"> 1. Adjust or replace the locking plate 2. Tighten the screws
The pedal cannot be positioned in the working position	Damaged return spring	Replace the spring
Difficulty in the operation of the tire pressure device	<ol style="list-style-type: none"> 1. Muffler failure 2. The cylinder sealing ring of the tire pressing device is damaged 	<ol style="list-style-type: none"> 1. Clean or replace the muffler 2. Replace the sealing ring

13. Technical parameter

Power Supply Voltage	110 V, 60 Hz, 1 Ph
Motor	1.5 HP (1.1 kW)
Working Pressure	116 PSI - 145 PSI (8 bar - 10 bar)
Bead Breaker Force	Pneumatic 5500 lbs
Drive System Type	Electric / Pneumatic
Table Clamping	Dual Pneumatic Cylinders
Bead Breaking System	Adjustable Pneumatic Blade
External Rim Clamping	12" - 22" (305 mm – 559 mm)
Internal Rim Clamping	13" - 24" (330 mm - 609 mm)
Max. Wheel Width	13" (330 mm)
Max. Wheel Diameter	41" (1040 mm)
Turntable Rotating Torque	885 ft/lbs
Power Cord Length	78 47/64" (2000 mm)
Speed	7 RPM
Turntable Tire Width Capacity (Mounting)	5" - 12" (127 mm - 305 mm)
Bead Breaker Tire Width Capacity (Demounting)	1 1/2" - 13" (38 mm - 330 mm)
Noise Level	<70 dB
Product Dimensions	L 43.3" x W 60.63" x H 76.18" (1100 mm x 1540 mm x 1935 mm)
Product Weight	515.88 lbs (234 kg)

14. Wiring diagram

